

VARISPEED L7

Sample Units Start Up Manual

This Start-Up Assistant is prepared in order to simplify the start up of Varispeed L7. For the description of the standard Varispeed F7 functions please refer to the instruction manual Noxxxxxxx.2

1 Wiring, Terminals:	2
1. Start up Procedure	3
2. Sequence for Speed Selections	3
Parameter	3
2.1 Higher Speed has priority, levelling speed is set at one Multi Function D/I (H1-xx=83) Settings: D1-19= 1, H1-01=80 (D1-09=50Hz), H1-02= 83 (D1-17-4Hz), H1-03=84 (d1-14=25Hz).....	3
Higher Speed has priority, levelling speed (H1-xx=83) is not set at one Multi Function D/I	3
Levelling Speed DI is in this case free programmable!2.2 Levelling Speed has priority (leveling speed like jog).....	3
2.2 Levelling Speed has priority (leveling speed like jog)	3
Levelling / Speed selection= 2 (rated speed at no speed reference, customer request)	3
2.3 Speed Selection Table	3
3. Tuning Parameters	3
Acceleration and Jerk Settings	3
3.1 Brake Control	3
3.2 Dwell at start function	3
3.3. Automatic Speed Regulator (Closed Vector control only)	3
3.4. Inertia Compensation.....	3
Parameter No	3
3.5 Slip compensation for V/f and Open loop vector	3
3.6. Short Floor Operation.....	3
4. Monitoring.....	3
5. Battery Operation	3
6 Programmable Digital Input Functions	3
7 Programmable Digital Output Functions.....	3
8 Fault Categories and Fault Reset	3
Alarm code	3
Fault 2 (non resetable fault).....	3
9 Special Fault commands	3
9.1 Contactor Feed-back Faults	3
9.2 Motor Low current Fault (MLC)	3
9.3 Car Stacked (OL4).....	3
7.3.3 Reference missing.....	3
10. Monitoring.....	3
11. Parameter List.....	3

This Start-Up Assistant is prepared in order to simplify the start up of Varispeed L7. For the description of the standard Varispeed F7 functions please refer to the instruction manual Noxxxxxxx.

1 Wiring, Terminals:

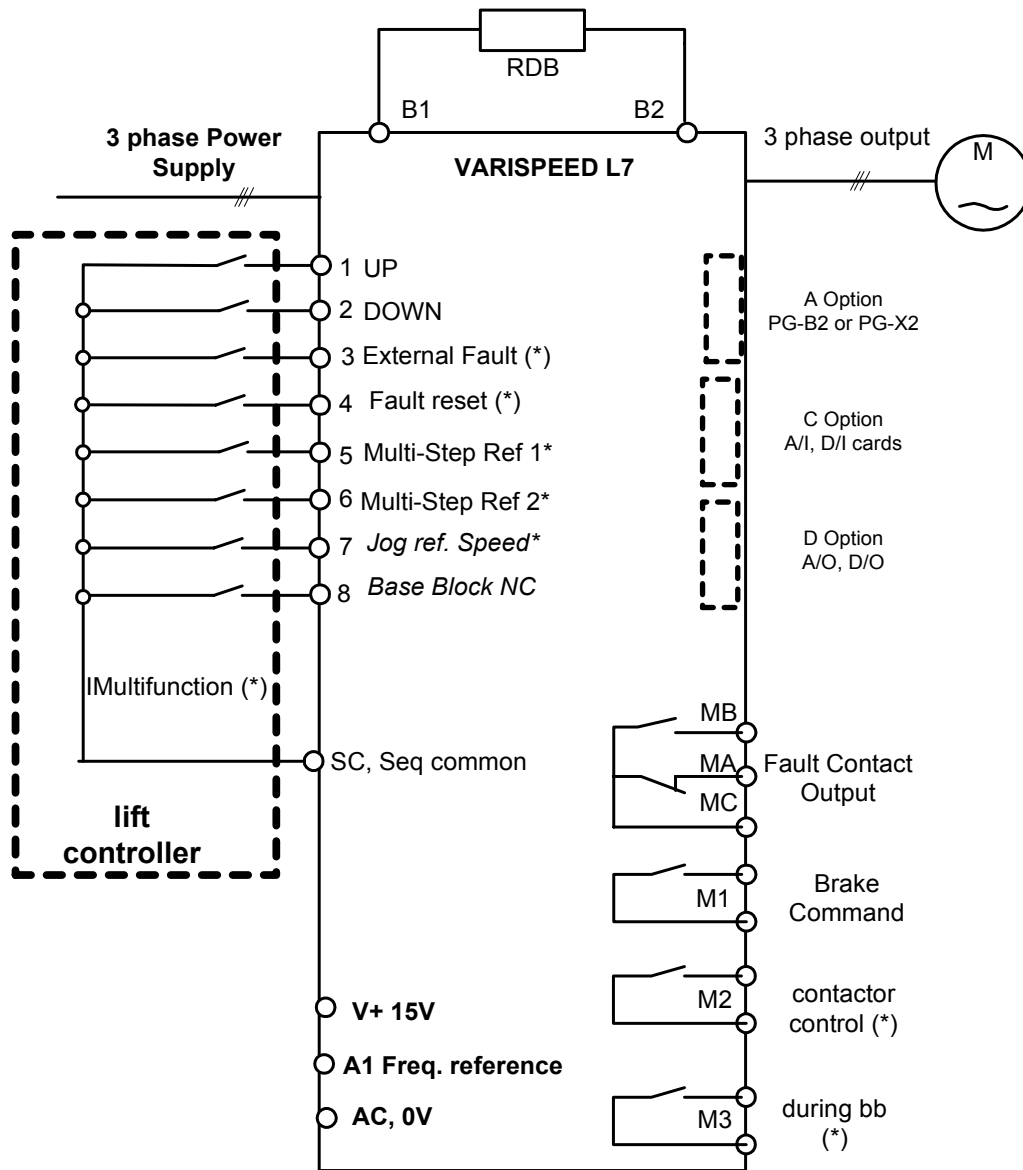

S8=BB

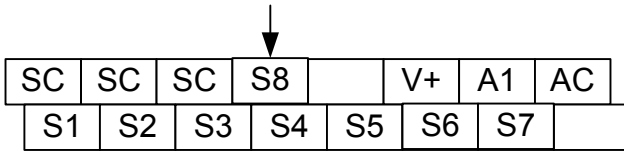

Digital Input Selection npn / pnp

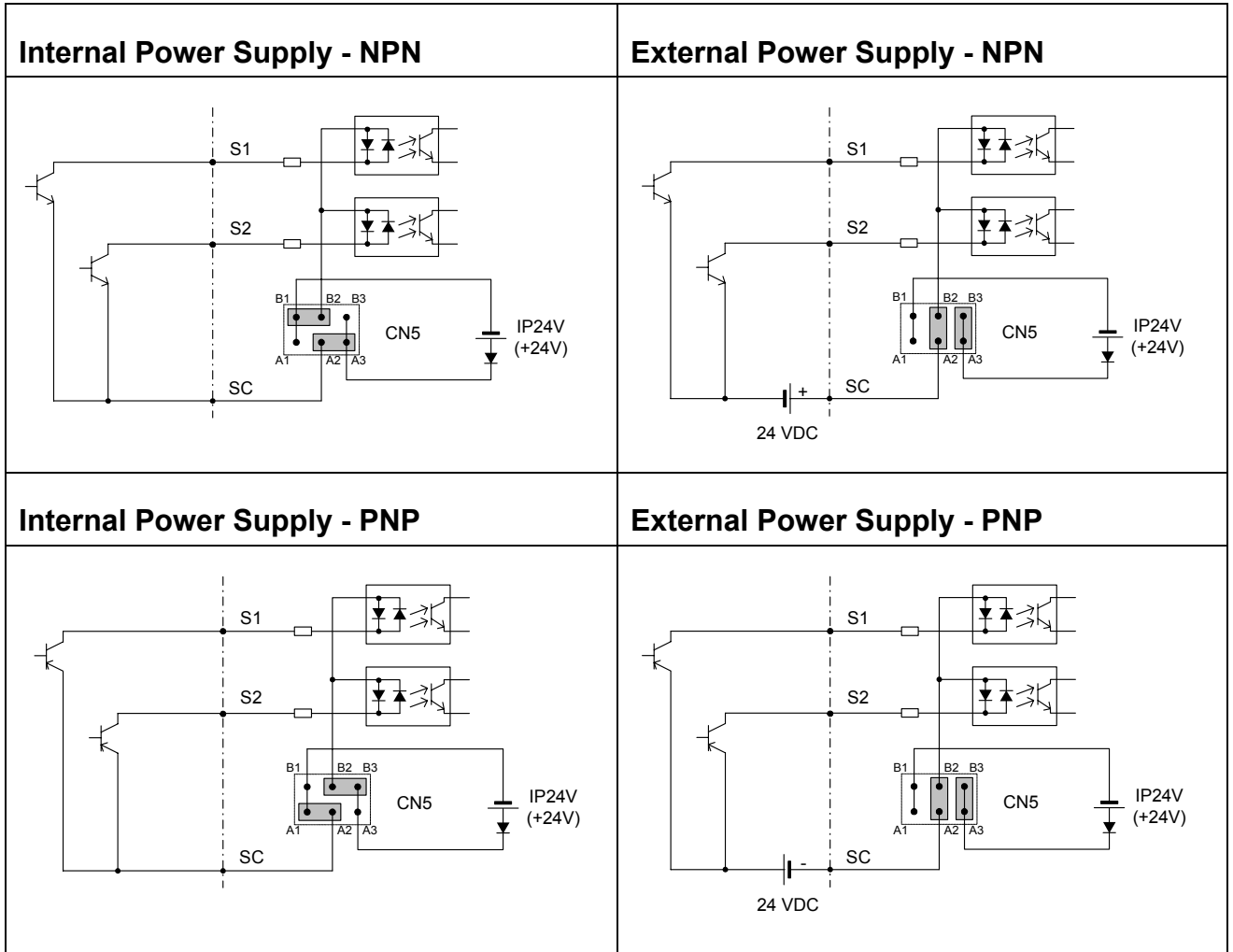

1. Start up Procedure

1. Before getting Start Up

Varispeed L7 is delivered with “LED monitor” JVOP 160 is needed to Start Up

2. Initialization of the Unit

Select Inverter Model, parameter **O2-04**

Initialize the inverter

Select: Control Methode in parameter **A1-02**

Select: 2-wire Initialisation in Parameter **A1-03**

3. Select the needed Sequence

The delivered units have as factory default standard F7 setting.

Select needed sequence at parameter in **D1-18 (see chapter 2)**

For short floor operation, feed forward type slip compensation D1-01 must be set 1 or 2

4. Select the speeds

If D1-18 is set 1 or 2, then following parameter are active for speed selection:

D1-09 vn (Nominal Speed)

D1-14 vi (Inspection Speed

D1-17 vl (Leveling Speed)

5. Motor Set Up(In vector Control)

Bring the car to the first floor

Proceed Auto Tuning. After Auto Tuning, first travel should be in up direction for 2-3 floors distance.
(minimum 40% of top speed must be reached)

After Auto Tuning confirm with name plate: Motor Rated Slip (**E2-02**) and No-Load Current (**E2-03**)

Motor Rated Slip must be between: 2-5Hz, Motor No-Load Current 30-60%.

Note: Before Starting “Proceed with Auto Tuning”, the motor contactor should be closed, till Auto Tuning is ended.

6. Trial Operation

At open loop control feed forward type slip compensation (S1-xx) is acting additional to standard slip compensation. Therefore motoring site levelling speed might be higher than set value. Please monitor and adjust S1-02 and C3-01 to have same speed in both directions.

2. Sequence for Speed Selections

Parameter	Range	Default	Description
D1-18 Speed reference priority	0,1,2		0= original multi-speed selection function, refer to G5 / FV manual set the speed reference at D1-01 to D1-08, D1-17 1=Higher speed has priority set the speed reference at D1-09 to D1-17 2=levelling speed has priority set the speed reference at D1-09 to D1-17

2.1 Higher Speed has priority, levelling speed is set at one Multi Function D/I (H1-xx=83)

Settings: D1-19= 1, H1-01=80 (D1-09=50Hz), H1-02= 83 (D1-17=4Hz), H1-03=84 (d1-14=25Hz)

At start, Selected Speed and levelling speed are set together. With taking away of selected speed, inverter decelerates to levelling frequency. Taking away of levelling speed triggers stopping.

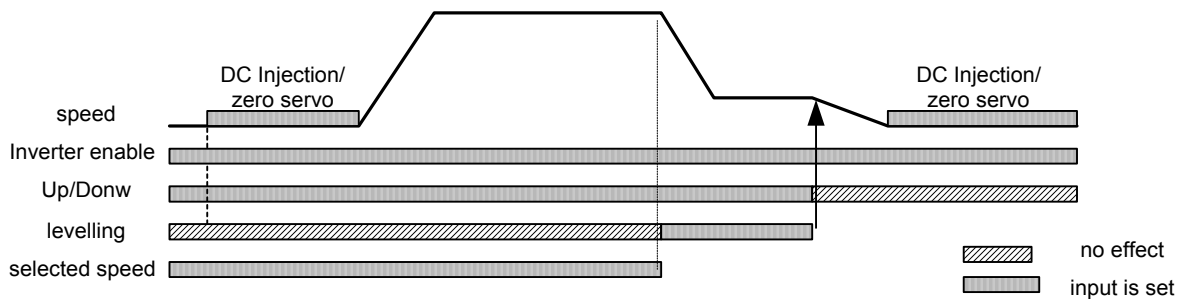

Inverter can also be stopped, when direction signal removed, instead of leveling signal!

Higher Speed has priority, levelling speed (H1-xx≠83) is not set at one Multi Function D/I

Settings: D1-19= 1 H1-01=80 D1-09=50Hz, H1-02= D1-17= 4Hz, H1-03=84 (d1-14=25Hz)

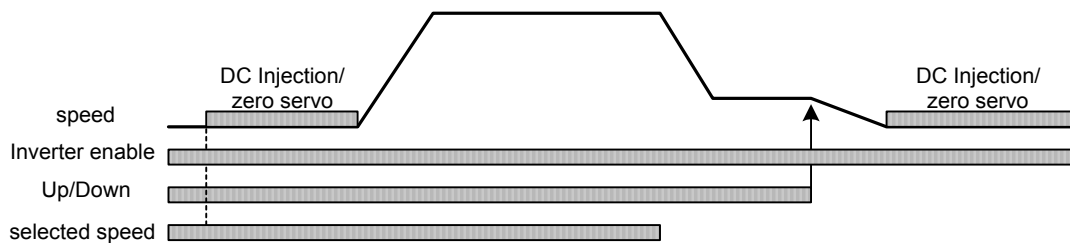

If no speed reference is selected inverter reference is levelling speed (like D1-01= leveling speed). Stopping is only possible with taking away of direction signal
 At start, a speed must be selected; otherwise inverter will output "No Reference Fault".
 Levelling Speed DI is in this case free programmable!

2.2 Levelling Speed has priority (leveling speed like jog)

Settings: D1-19= 2, H1-01=80, (D1-09=50Hz), H1-02= 83 (D1-17-4Hz), H1-03=84 (d1-14=25Hz)
 In this case selected speed is set at starting, inputting of levelling command triggers deceleration.
 Two possibilities to stop:

Possibility 1: inverter stops with taking away of the direction signal

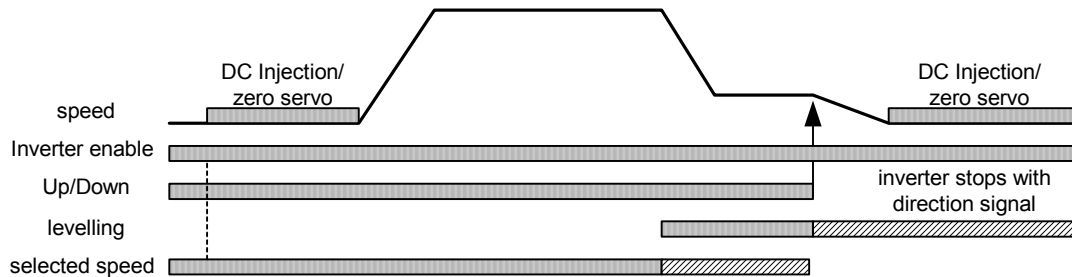

Possibility 2: inverter stops with taking away of the levelling signal

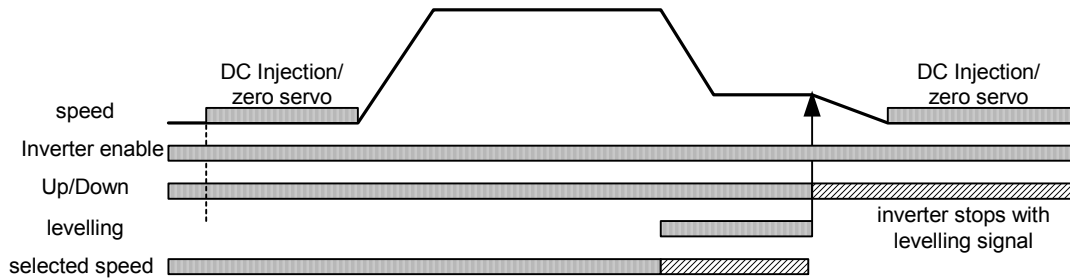

Levelling / Speed selection= 2 (rated speed at no speed reference, customer request)

Settings: D1-19= 2, (D1-09=50Hz), H1-02= 83 (D1-17-4Hz), H1-03=84 (d1-14=25Hz)
 If no speed reference is selected then the speed reference is v_n (like D1-01 = nominal speed).
 This function should allow the compatibility, because many installations run in this way. But this function is not allowed for lift application, because at wire brake, the reference should be zero!!!!

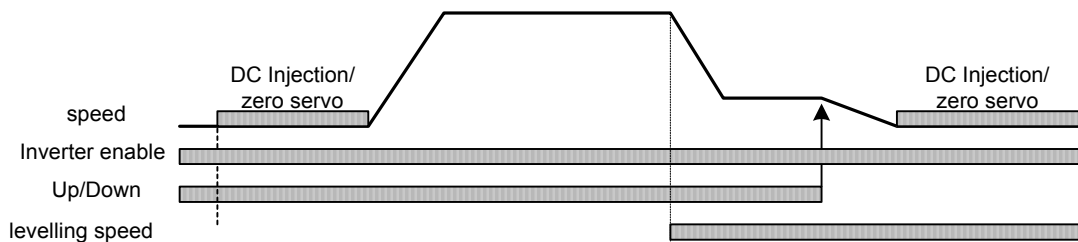

2.3 Speed Selection Table

1. High speed has priority and leveling speed command is set to multi-function digital input .

Terminal function	Vn	V1	V2	V3	Vr	VI	0Hz
Nominal Speed command	1	0	1	0	0	0	0
Intermediate speed command	0	1	1	1	0	0	0
Releveling speed command	0	0	1	1	1	0	0
Leveling speed command	X	X	X	X	X	1	0

To stop the inverter, all speed command signals or direction signals must be removed.

2. High speed has priority and Leveling speed command is not set to multi-function digital input .

Terminal function	Vn	V1	V2	V3	Vr	VI
Nominal Speed command	1	0	1	0	0	0
Intermediate speed command	0	1	1	1	0	0
Releveling speed command	0	0	1	1	1	0
Leveling speed command	N/A	N/A	N/A	N/A	N/A	N/A

To stop the inverter, all speed command signals or direction signals must be removed.

3. Leveling speed has priority and nominal speed command is set to multi-function digital input .

Terminal function	Vn	V1	V2	V3	Vr	VI	0Hz
Nominal Speed command	1	0	1	0	0	0	0
Intermediate speed command	0	1	1	1	0	0	0
Releveling speed command	0	0	1	1	1	0	0
Leveling speed command	X	X	X	X	X	1	0

To stop the inverter, all speed command signals or direction signals must be removed.

4. Leveling speed has priority and nominal speed command is not set to terminal.

Terminal function	Vn	V1	V2	V3	Vr	VI
Nominal Speed command	N/A	N/A		N/A	N/A	N/A
Intermediate speed command	0	1		1	0	X
Releveling speed command	0	0		1	1	X
Leveling speed command	0	0		0	0	1

To stop the inverter, all speed command signals or direction signals must be removed.

X = no effect, 1= set, 0= not set

vn- Nominal speed
 vl- Levelling Speed
 vi- Inspection Speed
 vr- Releveling Speed
 v1- Intermediate Speed 1
 v2- Intermediate Speed 2
 v3- Intermediate Speed 3

3.Tuning Parameters

For tuning of the lift, following zones are defined:

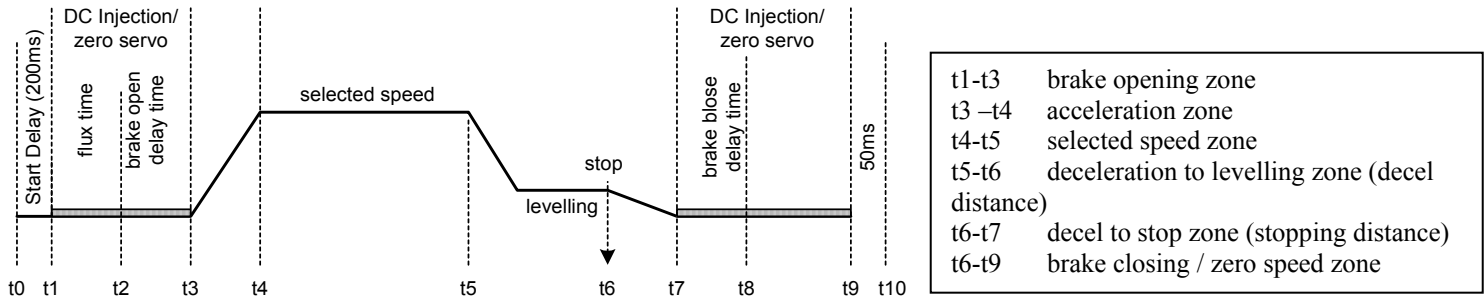

Acceleration and Jerk Settings

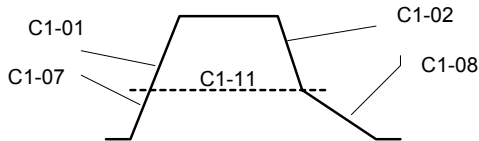

C1-01 is the acceleration rate. Deceleration rate is switched over from C1-02 to C1-08 T the frequency set in parameter C1-11.

C2-01, C2-02, C2-03, C2-0, C2-05



3.1 Brake Control

Brake Control parameters are simplified at L7. There are only two accessible brake parameters available. Brake opens, after internal run “*Magnetization Time*” . Inverter continues then DC injection (zero servo) for the time “*Brake Open Delay Time*”, before increasing the fout.

Before opening the brake and all time when brake is opened inverter checks the output current of the inverter. It must be always above parameter “*Brake Open Current*” (1/4 Noload current). If this current is not reached within MLC detection time or if the current is dropped after brake opening below this level, inverter will output fault message (MLC= Motor Low Current)

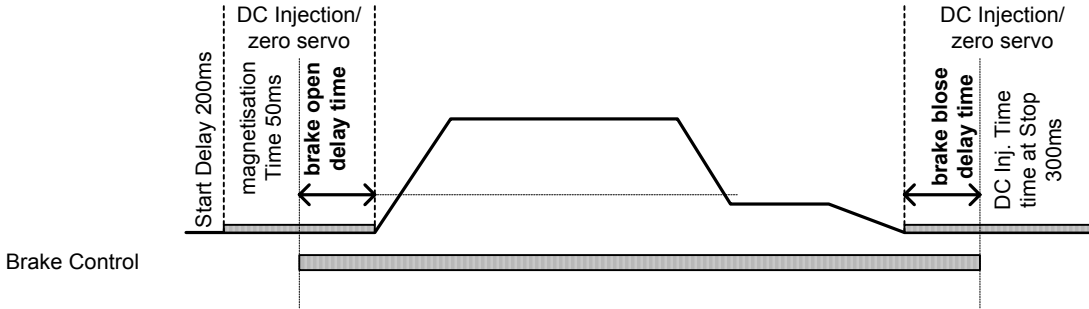

Only “*Brake Open Delay Time*” and “*Brake Close Delay Time*” are TUNING “TU” Parameters.

3.2 Dwell at start function

When S1-15 (dwell speed reference) is set , the Dwell at start function is activated. When the inverter starts, the inverter accelerates to S1-05 speed with C1-07 acceleration time. Once the motor speed exceeds the C1-11 frequency, the inverter will use the original acceleration time.

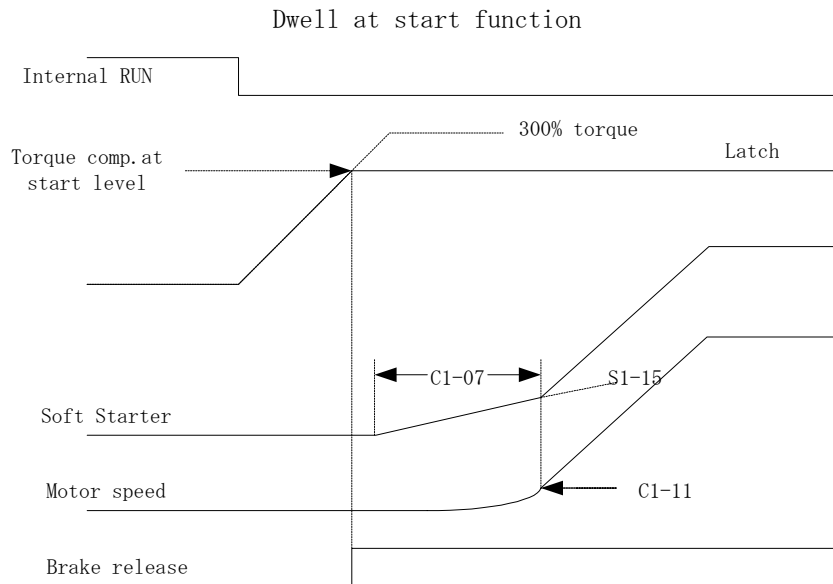

3.3. Automatic Speed Regulator (Closed Vector control only)

L7 has two sets of ASR parameters. One is for acceleration , the other is for decelerate to the leveling speed.

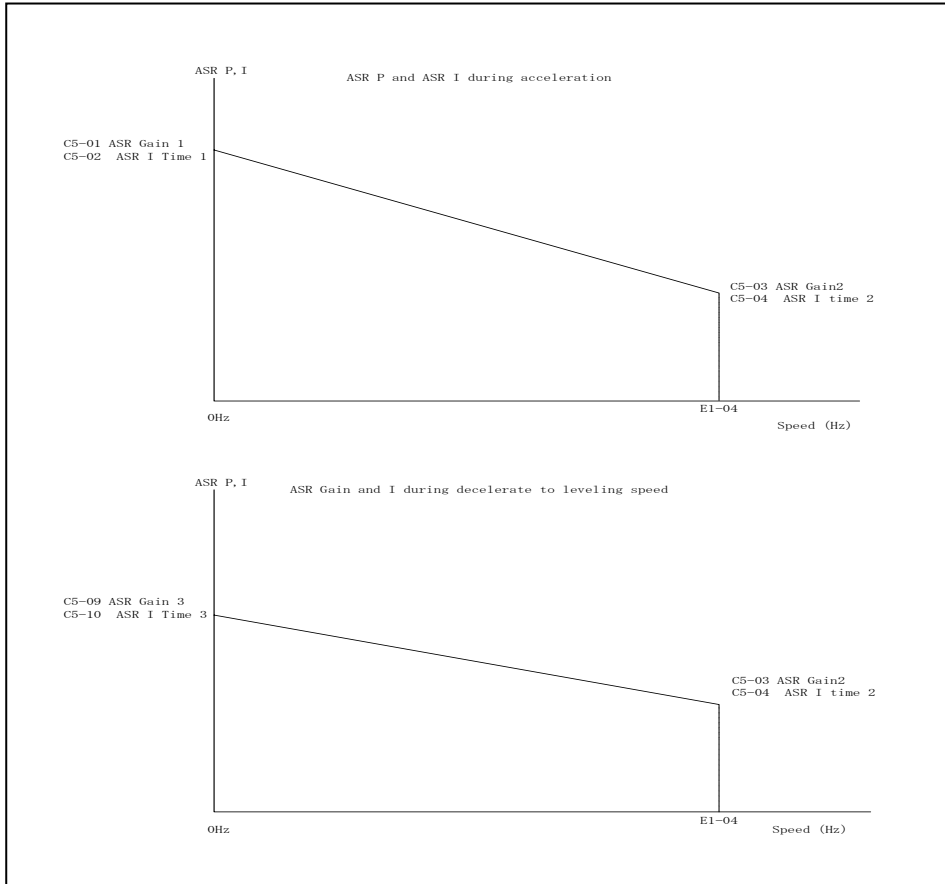

3.4. Inertia Compensation

To eliminate the overshoot or undershoot of speed, L7 has the feed forward control . There are two parameters. One is for estimated acceleration time to the rated speed with motor rated torque. The other is the feed forward proportional gain for fine tuning,

Parameter No	Name	Setting
N5-01	Feed forward control selection	0:disabled 1:enabled
N5-02	Motor acceleration time	Sec
N5-03	Feed forward proportional gain	

3.5 Slip compensation for V/f and Open loop vector

To obtain better leveling accuracy, smooth brake closing and leveling current reduction.
 To use this function, d1-18 must be set to 1 or 2.

Principle:

200ms after speed-agree (selected speed, vn, v1, v2 or v3), inverter measures for 200ms the current or torque reference and calculates average value for this time period. This amount of **EST(= End Speed Torque,current)** will be used for the calculation of slip . This amount of slip can be applied the speed reference when inverter is running at the leveling speed.
 Speed-agree time (approx.200ms) and measurement time must be factory level parameters

Note: For “*Inspection Speed, vi*” the described functions are not applicable, because a motor coasts to stop (base block) by the stop command.

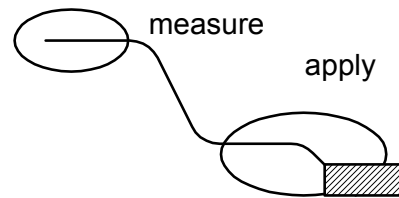

Setting parameters:

Parameter No	Name	Unit	V/f W/o PG	OLV	CLV
S2-01	Motor rated speed	RPM	○	×	×
S2-02	Slip comp gain at motoring		○	○	×
S2-03	Slip comp gain at regen		○	○	×
S2-04	Slip comp limit	%	○	○	×
S2-05	Torque detection delay time	ms	○	○	×
S2-06	Torque detection filtering time	ms	○	○	×
S2-07	Slip comp delay time	sec	×	○	×
U1-50	Slip comp value monitor	Hz	○	○	×

V/f mode slip compensation

The following block diagram is shown the slip compensation at V/f mode.

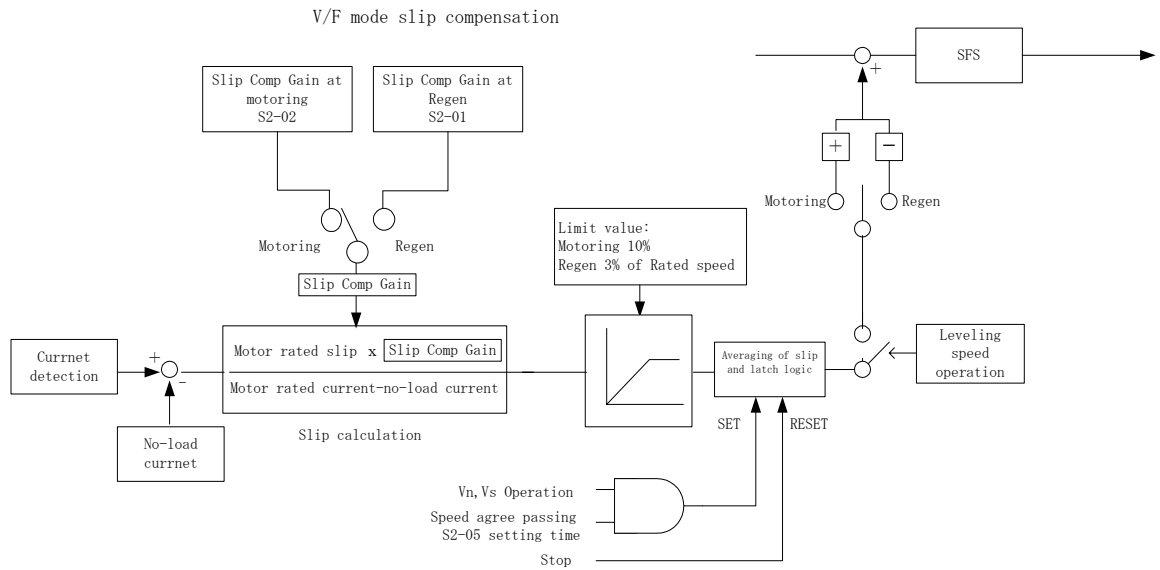

OLV mode slip compensation

The following block diagram is shown the slip compensation at OLV mode.

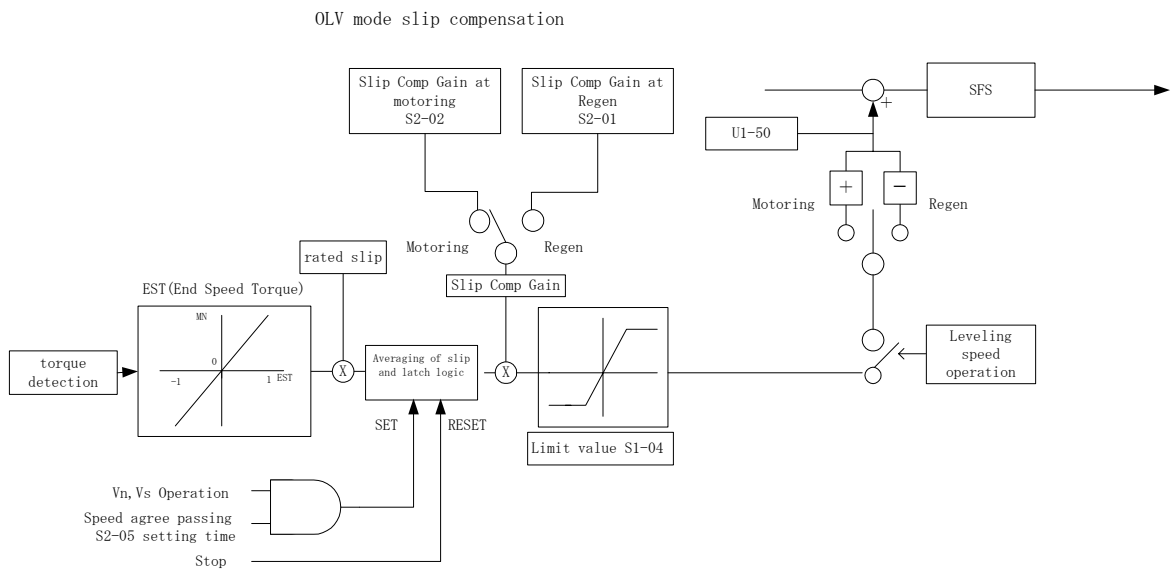

3.6. Short Floor Operation

The short floor operation can be selected when S3-03 parameter is set to 1.

Basic operation of short floor

The distance from V_n to V_j is calculated, which is the area shown below.

V_n : nominal speed V_j : leveling speed
 T_1 : S-curve time from top T_2 : S-curve time at stop

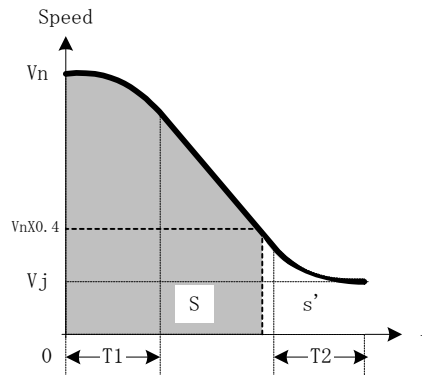

When decelerating from V_n speed, the distance to the leveling speed is same as the above

Area(S), therefore inverter follows the decel time and s-curve times as same as above setting.

But if the inverter is running with the speed V_s which is lower than V_n , the inverter keeps running

at V_{std} speed (which is 40% of V_n) until the remaining distance is the same as S'

This means that the inverter controls the operation time until S_2 being equal to S' distance.

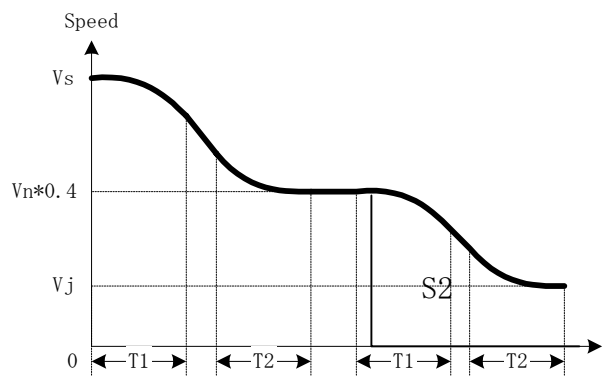

When the V_s is lower than 40% of V_n speed, the inverter accelerates to 40% of V_n speed.
 When The remaining distance is equal to the S' , the inverter starts decelerating.

4. Monitoring

Following monitor parameters are added to the existing ones.

Total working hours
Total RUN hours
Number of Travels
Imax @ accel
Imax @ decel
Imax @ top speed
Imax @ levelling speed
Distance to stop contact

Parameter: clear monitoring content (to see data for next run)

5. Battery Operation

Battery operation wiring

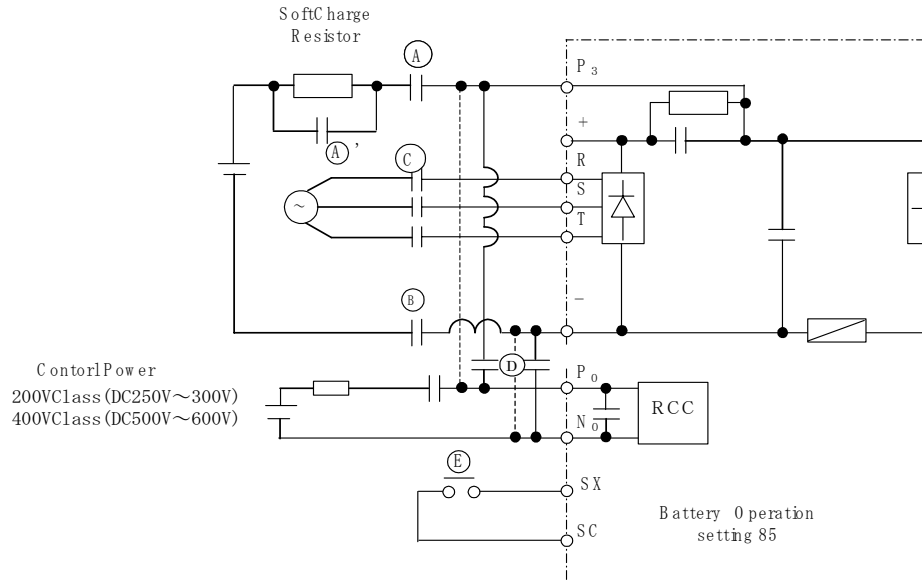

Battery sequence

The following timing chart shows the sequence of battery operation.

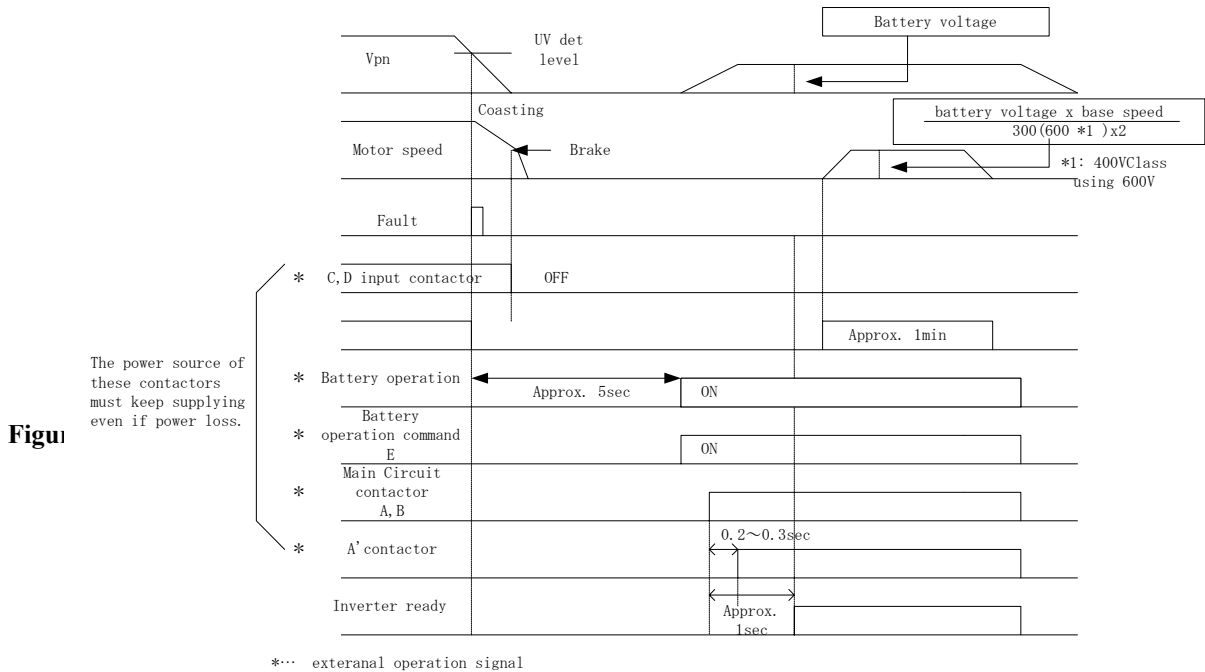

The sequence of switching the battery

1. When the bus voltage is below the under voltage level, the inverter detects the under voltage(UV) fault.
2. Turn off the RUN command.
3. C and D contactors must be turned off and turn on the motor mechanical brake.
4. Need the approx. 5sec to start battery operation.
5. The multi-function digital input which is assigned with the battery operation command(E) must be turned ON.
6. A' contactor must be turned ON after passing 0.2~0.3 sec when A and B main contactors are turned ON.
7. The RUN commands turns ON after inverter ready status set.
The battery operation time must be within 1min.
8. E, A, B and A' contactors must be turned OFF after RUN command OFF.
(Finish the battery operation.)

Note)

1. Battery voltage setting
When using the battery operation , the voltage of battery must be set to S3-06.
2. Battery operation speed
The speed during the battery operation will be limited as the following formula.

$$\text{Speed during battery operation} = (\text{battery voltage} \times \text{base speed}) / (300V \times 2)$$

When the 400V Class will be 600V

3. Continuous operation is prohibited.
The cooling fan of inverter is stopped due to the low bus voltage.
Therefore the continuous operation of inverter is prohibited.

Battery selection

Use the following battery

	200V Class	400V Class
Main bus voltage	48V	96V
Control voltage	200V	400V

Note) Main bus voltage during battery operation is decided based on the 10% of motor base speed.

Voltage drop must be less than 5% under the following load condition.

Current of control power : 50W/ control voltage

Current of main power : (motor rated power x speed during battery operation x 200%) /
(battery voltage x 60%(motor efficiency) x motor base speed)

6 Programmable Digital Input Functions

L7 has 5 Programmable D/Is.

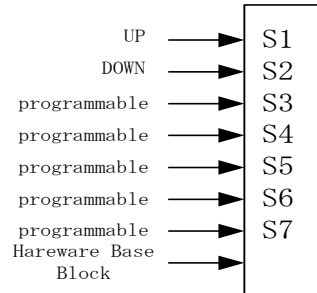

L7 has function selection of D/Is as the following table.

Setting	Function	Control mode				Note
		V/f W/O PG		OLV	CLV	
3	Multi-step speed 1	○		○	○	
4	Multi-step speed 2	○		○	○	
5	Multi-step speed 3	○		○	○	
6	JOG frequency	○		○	○	
7	Accel/Decel switch over1	○		○	○	
8	Base Block NO	○		○	○	
9	Base Block NC	○		○	○	
F	Not used	—		—	—	
14	Fault reset	○		○	○	
15	Fast Stop NO	○		○	○	
17	Fast Stop NC	○		○	○	
20~2F	External Fault input	○		○	○	
67	Memobus test mode	○		○	○	
80	Nominal Speed Command	○		○	○	NEW
81	Intermediate Speed Command	○		○	○	NEW
82	Releveling Speed Command	○		○	○	NEW
83	Leveling Speed Command	○		○	○	NEW
84	Inspection Run Command	○		○	○	NEW
85	Battery Operation Command	○		○	○	NEW
86	Contactorm conformation	○		○	○	NEW
87	High Speed Limit Switch UP	○		○	○	NEW
88	High Speed Limit Switch Down	○		○	○	NEW

High Speed Limit Switch UP

If this input is set, inverter will run jog speed reference at UP direction. Down direction no limitation.

High Speed Limit Switch Down

If this input is set, inverter will run jog speed reference at Down direction. UP direction no limitation.

7 Programmable Digital Output Functions

Multi-function digital output can be selected the following functions.

Setting	Function	Control mode				Note
		V/f W/O PG		OLV	CLV	
0	During running	○		○	○	
1	Zero speed	○		○	○	
2	Speed agreed	○		○	○	
3	Desired speed agree	○		○	○	
4	Frequency detection output1 (ON : +L4-01>=Output Frequency>=-L4-01, Width L4-02)	○		○	○	
5	Frequency detection output2 (ON : Output Frequency>=+L4-01 or Output Frequency<=-L4-01 , Width L4-02)	○		○	○	
6	Inverter ready	○		○	○	
7	UV detected	○		○	○	
8	Base Block NO	○		○	○	
9	Frequency reference selection (ON: from operator)	○		○	○	
A	RUN command selection (ON: from operator)	○		○	○	
B	Overtorque /undertorque detection1 NO	○		○	○	
C	Loss of frequency reference	○		○	○	
D	Braking resistor fault	○		○	○	
E	Fault (except CPF00,CPF01)	○		○	○	
F	Not used	—		—	—	
10	Minor fault	○		○	○	
11	Fault reset command active	○		○	○	
13	Frequency agree 3 (L4-04 used)	○		○	○	
14	Desired frequency agree 2(ON: Output frequency = L4-03)	○		○	○	
15	Frequency detection 3 (ON: Output frequency <=-L4-03,width L4-04)	○		○	○	
16	Frequency detection 4 (ON: Output frequency >=-L4-03,width L4-04)	○		○	○	
17	Overtorque/undertorque detection 1 NC	○		○	○	
18	Overtorque/undertorque detection 2 NO	○		○	○	
19	Overtorque/undertorque detection 2 NC	○		○	○	
1A	During reverse run	○		○	○	
1B	During base block 2	○		○	○	
1D	During regen mode	×		×	○	
1E	During fault retry	○		○	○	
1F	Motor overload pre-alarm	○		○	○	
20	Inverter over-heat pre-alarm	○		○	○	
30	During torque limit	×		○	○	
31	During speed limit	×		×	○	

Setting	Funciton	Control mode				Note
		V/f W/O PG		OLV	CLV	
33	Zero servo completion	x		x	o	
37	During run 2	o		o	o	
40	Brake release command	o		o	o	New
41	Contactore close command	o		o	o	New
42	Speed Level @ Decel	o		o	o	New
43	Not Zero Speed	o		o	o	New

8 Fault Categories and Fault Reset

L7 has one Alarm and two Fault Categories.

Alarm Inverter continues Running and alarm D/O will be set.

Fault 1 Inverter will stop, the fault output relay is activated immediately.
Reset command can be acceptable when the fault condition gone.

Fault 2 Fault categorized as the fault 2 cannot be reset until cycled the power.

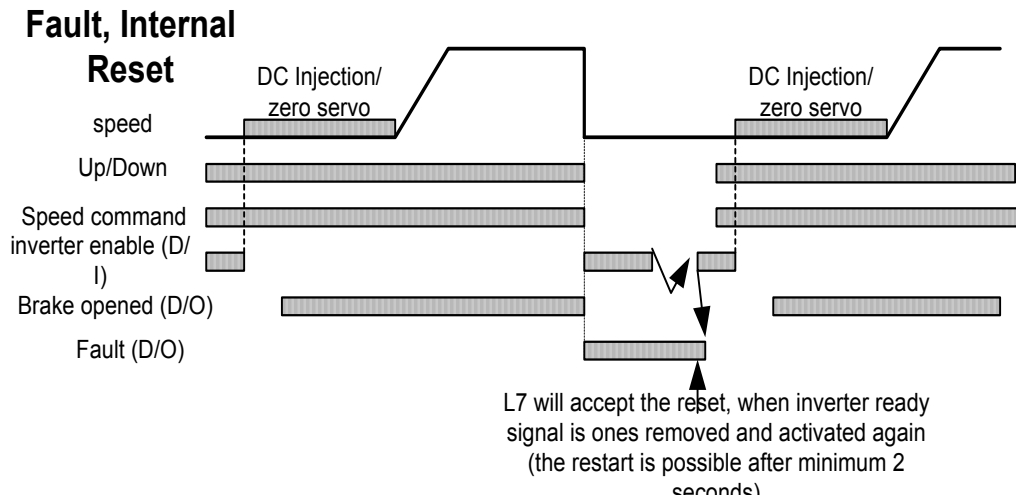

Alarm code

Alarm	EF	External Fault	Forward and reverse commands input together
	UV	Under voltage	Main circuit under voltage condition (not inverter running)
	OV	Over voltage	Main circuit DC voltage exceeds the overvoltage detection level
	OH	Over heating	Cooling fin temperature exceeds L8-02 pre-alarm level
	OL3	Overtorque detection 1	The inverter output current exceeds L6-02 level for L6-03 time
	OL4	Overtorque detection 2	The inverter output current exceeds L6-05 level for L6-06 time
	UL3	Undertorque detection 1	The inverter output current reached below L6-02 for L6-03 time
	UL4	Undertorque detection 2	The inverter output current reached below L6-05 for L6-06 time
	OS	Overspeed	The motor speed from PG exceeds the F1-08 level for F1-09 time.
	PGO	PG disconnected	PG disconnected PG pulses aren't being input even if inverter running
	DEV	Excessive speed deviation	The speed deviation is greater than F1-10 for F1-11 time.
	EF1~7	External fault input	The multi-function digital input is programmed as the external fault. The terminal assigned EF is input.
	CE	Communication Error	Memobus communication is stopped for 2sec.

Fault 1 code (resetable fault)

Fault1	OC	Overcurrent	The inverter output current exceeded the overcurrent detection level. (Approx. 200% of rated current)
	GF	Ground Fault	The ground fault current at the inverter output exceeded approximately 50% of the inverter rated current.
	PUF	Fuse Blown	The fuse in the main circuit is blown. The main IGBT transistor has failed.
	OV	Main circuit Overvoltage	The main circuit DC voltage exceeded the overvoltage detection level.
	UV1	Main circuit Under voltage	The main circuit DC voltage is below the undervoltage detection level.
	UV2	Control Power Fault	The control power supply voltage dropped.
	UV3	Inrush prevention circuit fault	A fault occurred in the surge prevention circuit.
	PF	Main circuit Voltage fault	The main circuit DC voltage oscillates unusually.
	LF	Output Open Phase	An open-phase occurred at the inverter output .
	OH	Cooling fin Overheating	The temperature of the inverter's cooling fins exceeds the setting of L8-02.
	OH3	Motor Overheating Alarm	The inverter will stop or continue to operate according to the setting of L1-03.
	OH4	Motor overheating fault	The inverter will stop according to the setting of L1-04.
	RH	Installing Braking resistor overheating	Inverter calculates the time of Braking resistor overheating.
	RR	Installing Braking Resistor fault	The braking transistor is not operating properly.
	OL1	Motor Overload	The motor overload protection function has operated based on the internal electronic thermal value.
	OL2	Inverter Overload	The inverter overload protection function has operated based on the internal electronic thermal value.
	OL3	Overtorque Detection 1	There has been a current greater than the setting in L6-02 for L6-03 time.
	OL4	Overtorque Detection 2	There has been a current greater than the setting in L6-05 for L6-06 time.
	UL3	Undertorque Detection 1	There has been a current less than L6-02 for L6-03 time.
	UL4	Undertorque Detection 2	There has been a current less than L6-05 for L6-06 time.
	OS	Overspeed	The motor speed has been greater than the setting of F1-08 level for F1-09 setting time.
	PGO	PG disconnection Detected	There is no PG pulse input during motor running.
	DEV	Excessive Speed Deviation	The speed deviation has been greater than F1-10 setting level for F1-11 setting time.
	CF	Control Fault	The torque limit was reached continuously for 3 seconds or longer during deceleration stop at open-loop vector mode.
	EF0	External fault from Communication card	External fault command is received from the communication option card.
	EF3~6	External fault from Terminal	The terminal assigned the external fault is closed.

Fault1	SVE	Zero Servo fault	The rotation position moved during Zero Servo operation.
	CE	Memobus communication Error	The communication response cannot received for 2sec.
	SE1	Sequence Error 1	See section 7 (dedicated fault message)
	SE2	Sequence Error 2	See section 7 (dedicated fault message)
	SE3	Sequence Error 3	See section 7 (dedicated fault message)
	MLC	Motor low current	See section 7 (dedicated fault message)

Fault 2 (non resetable fault)

Fault2	CPF00	Main CPU down	Cannot establish the communication between inverter and the digital operator.
	CPF01	Main CPU down	After the communication established, communication error occurred between inverter and operator.
	CPF02	BaseBlock circuit error	The base block circuit in the control card has error.
	CPF03	EEPROM Error	The contents between EEPROM and RAM don't match.
	CPF04	A/D Error (CPU)	A/D error in the CPU occurs.
	CPF05	A/D Error(external)	External A/D Converter error occurs.
	CPF06	Option connection error	The option card is not connected properly.
	CPF07	ASIC RAM error	The internal RAM in the ASIC has error.
	CPF08	Watch dog timer fault	Watch dog timer counts out.
	CPF09	CPU/ASIC mutual Diagnosis fault	The mutual diagnosis between CPU and ASIC detects error.
	CPF10	ASIC version fault	ASIC version doesn't match.
	CPF20	A/D error in the option card	A/D conversion error occurs in the option card.
	CPF21	Self diagnosis error	Option card detects error during self diagnosis.
	CPF22	Model code error	Inverter doesn't recognize the option card.
CPF23	DP-RAM Error	Communication option detects the DP-RAM error.	

9 Special Fault commands

9.1 Contactor Feed-back Faults

(resetable Fault)

If one of the digital inputs is set for “Contactor Confirmation, there are 3 possibilities for a fault:

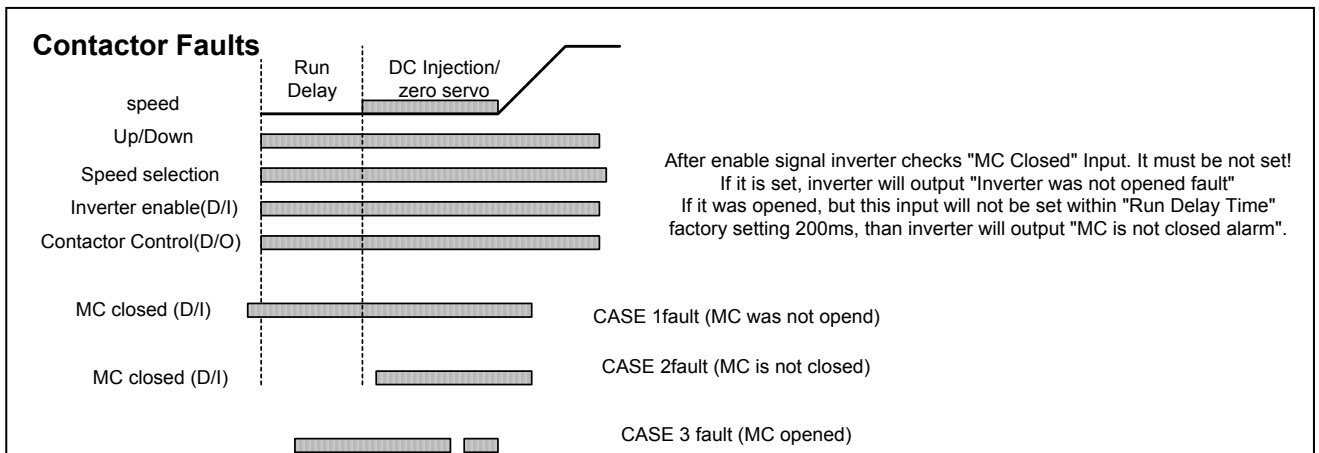

9.2 Motor Low current Fault (MLC)

(resetable Fault)

At Brake opening and after, always when brake is opened, inverter checks the motor Current. If it is dropped below (1/4) of Motor No Load Current, this Fault will be output. FaultType 1.

9.3 Car Stacked (OL4)

After new travel command (UP, Inverter ready, reference), inverter runs at torque limit or stall prevention limit for the Stacked car detection time.

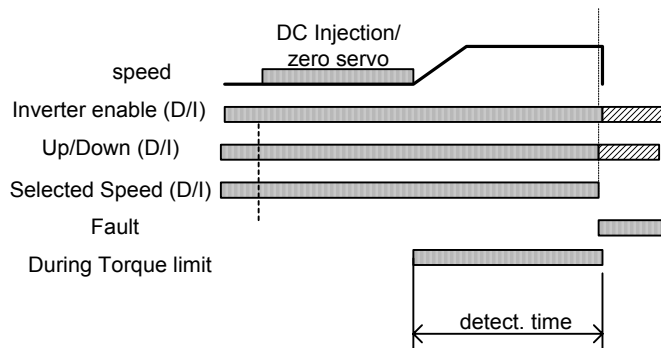

Check L6 parameters

7.3.3 Reference missing

At a new travel inverter got:
 Inverter ready signal
 Direction Signal
 but no reference within 200ms (Run delay time)

10. Monitoring

Following monitoring parameters are additional to the existing Varispeed F7 monitor functions:

U1-50	Speed Compensation value
U1-51	I max @ Accel
U1-52	I max @ Decel
U1-53	I max @ top speed
U1-54	I max @ levelling speed
U1-55	Number of Travels

Parameter: clear monitoring content (to see data for next run)

11. Parameter List

Function	Constant	Constant Name	Setting Possibilities	Default			Access Level		
				V/F	OLV	CLV	V/F	OLV	CLV
Initialize Menu									
Intialize Mode	A1-00	Language Selection	0: English 1: Japanese 2: German 3: French 4: Italian 5: Spanish 6: Portugese	0	0	0	A	A	A
	A1-01	Constant Acces Level	0: operation only 1: Start up and tuning 2: Advance parameters	2	2	2	A	A	A
	A1-02	Control Method	0: V/F control 2: OLV control 3: CLV control	0	2	3	Q	Q	Q
	A1-03	Inizialization	1110: Site Defaults 2220: 2 wire initialize				A	A	A
	A1-04	Password	0 to 9999				A	A	A
	A1-05	Password set	0 to 9999				A	A	A
Operation Mode Selections	B1-01	Reference Source	0: Digital Operator 1: Terminals 2: Memobus 3: Option Card	1 (1)	1	1	Q	Q	Q
	B1-02	Run Source	0: Digital Operator 1: Terminals 2: Memobus 3: Option Card	1	1	1	Q	Q	Q
	B1-03	stopping method	0: Deceleration to Stop 1: Coast To Stop	0	0	0	Q	Q	Q
	B1-06	Control input scan	0: 2ms 2 times 1: 5ms 2 times	1	1	1	A	A	A
	B1-07	operation after switching to remote mode	0: during switching disregarded 1: direct effective	0	0	0	A	A	A
	B1-08	run command selection in programming modes	0: can not operate 1: can operate	"0" 1	"0" 1	"0" 1	A	A	A
DC Injection Braking	b2-01 to 7	moved to S1							
	b2-08	magnetic flux compensation volume	0 to 1000%	NA	0	NA	NA	A	NA
DWELL function	B6-01	Dwell frequency at start	0 to 400.0 Hz	0	0	0	A	A	A

Yaskawa Electric Europe GmbH
Technical & Marketing Department
Drives Section

	B6-02	Dwell time at start	0.0 to 10.0sec	0	0	0	A	A	A
	B6-03	Dwell frequency at stop	0 to 400.0 Hz	0	0	0	A	A	A
	B6-04	Dwell time at stop	0.0 to 10.0sec	0	0	0	A	A	A
Acceleration/ Deceleration	C1-01	Accel Time 1	0 to 6000.0	10.0 sec "2.0"	10.0 sec "2.0"	10.0 sec "2.0"	Q	Q	Q
	C1-02	Decel Time 1					Q	Q	Q
	C1-03	Accel Time 2					A	A	A
	C1-04	Decel Time 2					A	A	A
	C1-05	Accel Time 3					A	A	A
	C1-06	Decel Time 3					A	A	A
	C1-07	Accel Time 4					A	A	A
	C1-08	Decel Time 4					A	A	A
	C1-09	Fast stop time					A	A	A
		C1-10					change of unit 0: 0.01 sec 1: 0.1 sec	change of unit 0: 0.01 sec 1: 0.1 sec	1
	C1-11	Decel Switch Frequency	0.0 to 400Hz	0	0	0	A	A	A
S-Curve	C2-01	S-Crv Acc @ Start	0.00 to 2.50 sec	0.5	0.5	0.5	A	A	A
	C2-02	S-Crv Acc @ End	0.00 to 2.50 sec	0.5	0.5	0.5	A	A	A
	C2-03	S-Crv Dec @ Start	0.00 to 2.50 sec	0.5	0.5	0.5	A	A	A
	C2-04	S-Crv Dec @ End	0.00 to 2.50 sec	0.5	0.5	0.5	A	A	A
Slip Compensation	C3-01	Slip compensation gain	0.0 to 2.5	1	1	1	A	A	A
	C3-02	Slip compensation delay time	0 to 10000msec	2000	200 "2000"	NA	A	A	NA
	C3-03	Slip compensation limit	0 to 250%	200	200	NA	A	A	NA
	C3-04	slip selection during generation	0: no slip compensation 1: slip compensation	0	0	NA	A	A	NA
	C3-05	Output voltage limit operation	0: disabled 1: enabled	NA	0	0	NA	A	A
	C3-06	flux calculation method	0: after correction of frequency flux calculation 1: before	NA	0	NA	NA	F	A
Torque Compensation	C4-01	Torque Comp. Gain	0.0 to 2.50	1.0	1.0	NA	A	A	NA
	C4-02	Torque Comp. Time	10 to 10000ms	200	20	NA	A	A	NA
	C4-03	Starting torque compensation (FWD)	0 to 200	NA	0	NA	NA	A	NA
	C4-04	Starting torque compensation (REV)	-200 to 0.0	NA	0	NA	NA	A	NA
	C4-05	starting torque compensation time constant	0 to 200	NA	10	NA	NA	A	NA
	C4-06	torque comp time	0 to 10000msec	NA	150	NA	NA	F	NA
Speed Control (ASR)	C5-01	ASR gain	0 to 300.00	N.A	N.A	20	N/A	N/A	A

Yaskawa Electric Europe GmbH
Technical & Marketing Department
Drives Section

	C5-02	ASR IntegralTime @ brake opening	0.000 to 10.000	N.A	N.A	0.5	N/A	N/A	A
	C5-03	ASR gain @ top speed	0 to 300.00	N.A	N.A	20	N/A	N/A	A
	C5-04	ASR IntegralTime @ top speed	0.000 to 10.000	N.A	N.A	0.5	N/A	N/A	A
	C5-06	ASR delay time	0.000 to 0.500	N.A	N.A	0.004	N/A	N/A	A
	C5-07	ASR gain change frequency	0.0 to 400Hz	N.A	N.A	0.0	N/A	N/A	A
	C5-08	ASR integral limit	0 to 400	N.A	N.A	400	N.A	N.A	A
	C5-09	ASR comp gain 3	0 to 300.00	N.A	N.A	20	N/A	N/A	A
	C5-10	ASR integral limit 2	0.000 to 10.000	N.A	N.A	0.5	N/A	N/A	A
	c6-02	carrier frequency selection only for F parameter 3 to 7 can be set	0 to F	3	3	3	Q	Q	Q
	C6-03	Carrier Frequency Upper Limit	2 to 15 kHz	8	8	8	A	A	A
	C6-04	Carrier frequency lower limit	0.4 to 15.0	8	N.A	N.A	A	N.A	N.A
	C6-05	gain	0 to 99	0	N.A	N.A	A	N.A	N.A
Preset References	d1-01	frequency 1	0.00 to 400.00	0	0	0	Q	Q	Q
	d1-02	frequency 2	0.00 to 400.00	0	0	0	Q	Q	Q
	d1-03	frequency 3	0.00 to 400.00	0	0	0	Q	Q	Q
	d1-04	frequency 4	0.00 to 400.00	0	0	0	Q	Q	Q
	d1-05	frequency 5	0.00 to 400.00	0	0	0	A	A	A
	d1-06	frequency 6	0.00 to 400.00	0	0	0	A	A	A
	d1-07	frequency 7	0.00 to 400.00	0	0	0	A	A	A
	d1-08	frequency 8	0.00 to 400.00	0	0	0	A	A	A
	d1-09	vn	0.00 to 400.00	0 "50"	0 "50"	0 "50"	A	A	A
	d1-10	v1	0.00 to 400.00	0	0	0	A	A	A
	d1-11	v2	0.00 to 400.00	0	0	0	A	A	A
	d1-12	v3	0.00 to 400.00	0	0	0	A	A	A
	d1-13	vr	0.00 to 400.00	0	0	0	A	A	A
	d1-14	vi	0.00 to 400.00	0 "25.0"	0 "25.0"	0 "25.0"	A	A	A
	d1-17	vl	0.00 to 400.00	0 "4.0"	0 "4.0"	0 "4.0"	A	A	A
	d1-18	speed priority selection	0: terminal 1: high speed high priority 2: leveling highest	0 "1"	0 "1"	0 "1"	A	A	A
field weakening level	d6-03	force field weaking selection	0: disabled 1: enabled	N/A	0	0	N/A	A	A
	d6-06	force filed weaking limit	100 ton 400%	N/A	400	400	N/A	A	A
V/f Pattern	E1-01	Inverter Input Voltage	310 to 510VAC*	400*	400*	400*	Q	Q	Q
	E1-03	V/f pattern selection	0 to E	F	N/A	N/A	Q	N/A	N/A
	E1-04	Max. Output Freq.	40 to 400Hz	60	60	60	Q	Q	Q
	E1-05	Motor Voltage	0.0 to 510V	400*	400*	400*	Q	Q	Q
	E1-06	Motor Frequency	0 to 400Hz	60	60	60	Q	Q	Q

Yaskawa Electric Europe GmbH
Technical & Marketing Department
Drives Section

	E1-07	Mid frequency	0 to 400Hz	3	3	3	A	A	F
	E1-08	Mid. Output Voltage @ 3Hz	0.0 to 510V	22*	22*	22*	A	A	F
	E1-09	Min frequency	0 to 400Hz	0.5	0.5	0.5	Q	Q	A
	E1-10	Min. Output Voltage @ 0.5Hz	0.0 to 510V	4*	4*	4*	A	A	F
	E1-11	middle frequency 2	0 to 400Hz	0	0	0	A	A	A
	E1-12	voltage at mid frequency 2	0.0 to 510V	0	0	0	A	A	A
	E1-13	base voltage	0.0 to 510V	0	0	0	A	Q	Q
Motor Setup	E2-01	Motor Rated Current					Q	Q	Q
	E2-02	Motor Rated Slip	0.00 to 20.00				A	A	A
	E2-03	Motor No Load Current (% to E2-01)					A	A	A
	E2-04	Number of poles	2 to 48	N.A	N.A	4	N.A	N.A	Q
	E2-05	Motor Line to Line Resistance	0.000 to 65.000				N.A	N.A	Q
	E2-06	motor leak inductance	0 to 40	18.2	18.2	18.2	N.A	A	A
	E2-07	motor iron saturation coef 1	0.00 to 50.0	N.A	0.5	0.5	N.A	A	A
	E2-08	motor iron saturation coef 2	0.00 to 0.75	N.A	0.75	0.75	N.A	A	A
	E2-09	mechanical motor loss	0.0 to 10.0	N.A	N.A	0	N.A	N.A	A
	E2-10	motor iron loss for torque compensation	0 to 65535		N.A	N.A	A	N.A	N.A
	E2-11	motor rated output power	0.00 to 650.00				Q	Q	Q
	F1-01	PG pulse per revolution	0 to 60000	N.A	N.A	1024	N.A	N.A	Q
	F1-02	Operation at PG open circuit	0 to 3	N.A	N.A	1	N.A	N.A	A
	F1-03	operation selection at overspeed	0 to 3	N.A	N.A	1	N.A	N.A	A
	F1-04	operation selection at deviation	0 to 3	N.A	N.A	3	N.A	N.A	A
	F1-05	PG Rotation	0: CW 1: CCW	N.A	N.A	0	N/A	N.A	A
	F1-06	PG division rate	1 to 132	N.A	N.A	1	N/A	N.A	A
	F1-08	overspeed detection level	0 to 120%	N.A	N.A	115%	N/A	N.A	A
	F1-09	over speed detection delay time	0 to 2.0sec	N.A	N.A	0.0sec	N/A	N.A	A
	F1-10	Excessive speed deviation detection level	0 to 50	N.A	N.A	10%	N/A	N.A	A
	F1-11	Excessive speed deviation detection delay time	0 to 10.0	N.A	N.A	0.5sec	N/A	N.A	A

Yaskawa Electric Europe GmbH
Technical & Marketing Department
Drives Section

	F1-14	Disconnection detection time to the PG	0 to 10.0	N.A	N.A	2sec	N/A	N.A	A
	F1-15	speed dection filter selection	0: no average 1: average over 8 values	N.A	N.A	1	N/A	N.A	F
Multi-function Analog Outputs "AOI Card Option"	F4-01	CH1 Analog Monitor selection	Select the function according to U1, monitor parameters	2	2	2	A	A	A
	F4-02	CH1 Analog Monitor gain	0 to 1000%	100	100	100	A	A	A
	F4-03	CH2 Analog monitor selection	1 to 99	3	3	3	A	A	A
	F4-04	CH2 Analog monitor gain	0 to 1000%	50	50	50	A	A	A
	F4-05	CH1 output monitor bias	-110 to 110%	0	0	0	A	A	A
	F4-06	CH2 output monitor bias	-110 to 110%	0	0	0	A	A	A
	F4-07	voltage selection of the analog output CH1	0: 0 to 10VDC 1: -10 to 10VDC	0	0	0	A	A	A
	F4-08	voltage selection of the analog output CH2	0: 0 to 10VDC 1: -10 to 10VDC	0	0	0	A	A	A
Digital output card	F5-01	number of the output function, if gate D0-08 enabled	0 to 37	0	0	0	A	A	A
	F5-02	number of the output function, if gate D0-08 enabled	0 to 37	1	1	1	A	A	A
	F5-03	number of the output function, if gate D0-08 enabled	0 to 37	2	2	2	A	A	A
	F5-04	number of the output function, if gate D0-08 enabled	0 to 37	4	4	4	A	A	A
	F5-05	number of the output function, if gate D0-08 enabled	0 to 37	6	6	6	A	A	A
	F5-06	number of the output function, if gate D0-08 enabled	0 to 37	37	37	37	A	A	A
	F5-07	number of the output function, if gate D0-08 enabled	0 to 37	F	F	F	A	A	A
	F5-08	number of the output function, if gate D0-08 enabled	0 to 37	F	F	F	A	A	A
	F5-09	output mode selection, if D0-08 is enabled	0 to 2	0	0	0	A	A	A
Communication option card	F6-01	operation selection after communication error	0 to 3	1	1	1	A	A	A
	F6-02	Input level of external error from from Communications Option card	0,1	0	0	0	A	A	A

Yaskawa Electric Europe GmbH
Technical & Marketing Department
Drives Section

	F6-03	Stopping method for external error from Communications Option card	0 to 3	1	1	1	A	A	A
	F6-04	Trace sampling from Communications Option card	0 to 60000	0	0	0	A	A	A
	F6-05	Current monitor unit selection	0,1	0	0	0	A	A	A
	F6-06	Selection of Torque signal / Torque limit for communication	0,1	0	0	0	N.A	N.A	A
Multifunction contact inputs H1	H1-01	S3 function selection	0 to 78	24	24	24	A	A	A
	H1-02	S4 function selection	0 to 78	14	14	14	A	A	A
	H1-03	S5 function selection	0 to 78	3	3	3	A	A	A
	H1-04	S6 function selection	0 to 78	4	4	4	A	A	A
	H1-05	S7 function selection	0 to 78	6	6	6	A	A	A
Analog inputs H2	H2-01	Terminal M1-M2 function selection, fixed	0 to 37	0	0	0	A	A	A
	H2-02	Terminal M3 M4 function selection	0 to 37	1	1	1	A	A	A
	H2-03	Terminal M5 M6 function selection	0 to 37	2	2	2	A	A	A
Analog Inputs	H3-01	Frequency reference signal A1 -14B CH1(voltage) level selection	0: 0 to 10V 1: -10 to 10V	0	0	0	A	A	A
	H3-02	fref gain	0.0 to 1000.0 %	100.0	100.0	100.0	A	A	A
	H3-03	fref bias	-100.0 to 100.0	0	0	0	A	A	A
	H3-04	Analog input A1-14B CH3 signal selection	0,1	0	0	0	A	A	A
	H3-05	CH3 function selection	0 to 1F	2	2	2	A	A	A
	H3-06	CH3 gain	0.0 to 1000.0 %	100.0	100.0	100.0	A	A	A
	H3-07	CH3 bias	-100.0 to 100.0	0	0	0	A	A	A
	H3-08	CH2 fref selction (current)	0: 0 to 10V 1: -10 to 10V 2: 4 to 20mA	2	2	2	A	A	A
	H3-09	CH2 function selection	0 to 1F	3	3	3	A	A	A
	H3-10	CH2 gain	0.0 to 1000.0 %	100.0	100.0	100.0	A	A	A
	H3-11	CH2 bias	-100.0 to 100.0	0	0	0	A	A	A
	H3-12	analog filter (CH1, CH2, CH3)	0.00 to 2.00sec	0.03	0.03	0.03	A	A	A
	H3-15	A1 analog input function	0: fref 1: torque	0	0	0	A	A	A
	H3-16	A1 gain	0.0 to 1000.0 %	100.0	100.0	100.0	A	A	A
	H3-17	A1 bias	-100.0 to 100.0	0	0	0	A	A	A

Yaskawa Electric Europe GmbH
Technical & Marketing Department
Drives Section

Motor Overload	L1-01	Motor Protection Selection	0: Disabled 1: General Purpose motor 2: Inverter Motor 3: Vector Motor	1	1	1	Q	Q	Q
	L1-02	Motor Protection Time Constant	0.1 to 5.0 min	1.0	1.0	1.0	A	A	A
Power loss Ridethrough	L2-05	Undervoltage detection level		190 (380)VDC	190 (380)VDC	190 (380)VDC	A	A	A
	L2-11	battery voltage		0	0	0	A	A	A
Stall Prevention Accel	L3-01	Stall Prevention acceleration	0: disabled 1: enabled	1	1	NA	A	A	NA
	L3-02	Stall prevention level accel	0 to 200	150	150%	N.A	A	A	N.A
	L3-03	stall prevention limit during acceleration	0 to 100	50%	50%	N.A	A	A	NA
	L3-04	Stall prevention decel	0: disabled 1: enabled 2: intelligent 3: brake resistor	1	1	1	Q	Q	Q
	L3-05	stall prevention selection during running	0: disabled 1: enabled, dec1 2: enabled, dec2	1	NA	NA	A	NA	NA
	L3-06	stall prevention level during running	30 to 200%	150	NA	NA	A	NA	NA
	L3-07	stall prevention P gain	0.1 to 2.00	1.00	NA	NA	F	NA	NA
	L3-08	stall prevention integral time	10 to 250sec	100	NA	NA	F	NA	NA
	L3-11	Stall prevention accel old level	0:disabled 1: enabled	NA	0	0	NA	A	A
	L3-12	Over Voltage supression level	350 to 390V	NA	380	380	NA	A	A
Reference Detection	L4-01	Speed Agree Level	0.0 to 400Hz	0	0	0	A	A	A
	L4-02	Speed Agree Level width	0.0 to 20.0	2	2	2	A	A	A
	L4-03	Speed agree level (+/-)	-400 to 400V	0	0	0	A	A	A
	L4-04	Speed agree detection width(+/-)	0.0 to 20.0	2	2	2	A	A	A
	L4-05	Operation when frequency reference is missing	0: stop 1: L4-06 as freq	0	0	0	A	A	A
	L4-06	frequency reference at frequency reference loss	0.0 to 100.0%	80.0	80.0	80.0	A	A	A
Fault Reset	L5-01	Nimber of Auto Reset	0 to 10	2	2	2	A	A	A

Yaskawa Electric Europe GmbH
Technical & Marketing Department
Drives Section

	L5-02	Fault Contact	0: not active 1: active	1	1	1	A	A	A
Torque Detection	L6-01	Over Load Detection Selection	0 to 8	0	0	0	A	A	A
	L6-02	Over Load Detection Level	0.0 to 300%	150%	150%	150%	A	A	A
	L6-03	Over Load Detection Time	0.0 to 10.0s	0.1	0.1	0.1	A	A	A
	L6-04	Over Torque detection selection 2	0 to 8	0	0	0	A	A	A
	L6-05	Over Torque detection level 2	0.0 to 300%	150%	150%	150%	A	A	A
	L6-06	Over Load Detection Time 2	0.0 to 10.0s	0.1	0.1	0.1	A	A	A
Torque Limits	L7-01	Forward Motoring Limit	0 to 300%	NA	200	200	NA	A	A
	L7-02	Reverse Motoring Limit	0 to 300%	NA	200	200	NA	A	A
	L7-03	Forward Regen Limit	0 to 300%	NA	200	200	NA	A	A
	L7-04	Reverse Regen Limit	0 to 300%	NA	200	200	NA	A	A
	L7-05	torque limit gain	0 to 10.0	NA	2	NA	NA	F	NA
	L7-06	torque limit integral time	5 to 10000	NA	200	NA	NA	A	NA
	L7-07	torque limit control mode	0,1	NA	0	NA	NA	A	NA
Hardware Protection	L8-01	Protect selection for internal DB resistor	0,1	0	0	0	A	A	A
	L8-02	Overheat Pre Alarm Level	50 to 130C	95	95	95	A	A	A
	L8-03	Operation after Overheat Pre Alarm	0: decel to stop (C1-02) 1: coast 2: fast stop (C1-09) 3: continue operation (Fault 2)	3	3	3	A	A	A
	L8-05	Input Power Loss Selection	0: disabled 1: enabled	1	1	1	A	A	A
	L8-06	phase loss detection level	0.0 to 50.0%	5	5	5	F	F	F
	L8-07	Output Open phase Loss Detection	0: disabled 1: enabled 1phase 2: enabled 2 phase	2	2	2	A	A	A
	L8-09	Ground Fault Detection	0: disabled 1: enabled	1	1	1	A	A	A
	L8-10	Cooling Fan Control	0: on when inverter is on 1: on when power is on 2: on when temperature is high L8-21	2	2	2	A	A	A
	L8-11	Cooling Fan Control Delay Time	0 to 300 s	60	60	60	A	A	A

Yaskawa Electric Europe GmbH
Technical & Marketing Department
Drives Section

	L8-12	Ambient temperature	45 to 60	45	45	45	A	A	A
	L8-13	UV3 detection selection	0,1	1	1	1	F	F	F
	L8-14	inverter over load protection selection	0,1	1	1	1	F	F	F
	L8-15	OL2 characteristic at Low speed	0: disabled 1: enabled	1	1	1	A	A	A
	L8-18	Soft CLA Selection	0: disabled 1: enabled	1	1	1	A	A	A
Fan Control	L8-20	Phase loss detection time	0.0 to 2.0sec	0.2	0.2	0.2	A	A	A
	L8-20	Fan Start Temp	40 to L8-02-20C	L8-02-20C	L8-02-20C	L8-02-20C	A	A	A
Hunting prevention	N1-01	Hunting prevention function selection	0: disabled 1: enabled	1	NA	NA	A	NA	NA
	N1-02	Hunting prevention gain	0 to 2.50	1.00	NA	NA	A	NA	NA
Speed Feedback Protection Control (AFR)	N2-01	AFR gain	0.00 to 10.00	N.A	1.00	N.A	N.A	A	N.A
	N2-02	AFR Time	0 to 2000 ms	N.A	50	N.A	N.A	A	N.A
	N2-03	AFR time 2	0 to 2000 ms	N.A	750	N.A	N.A	A	N.A
feed forward control	N5-01	feed forward control selection	0: disabled 1: enabled	N.A	N.A	1	N.A	N.A	A
	N5-02	motor acc time	0.001 to 10.000	N.A	N.A		N.A	N.A	A
	N5-03	gain	0.00 to 100.00	N.A	N.A	1.00	N.A	N.A	A
	N5-04	speed signal answer freq	0 to 50.00Hz	N.A	N.A	40.00Hz	N.A	N.A	F
fabric control parameter	N9-01	inverter rated current					F	F	F
	N9-16	IDFB filter	0.00 to 2.50 sec		1		NA	F	NA
	N9-17	R, Idfb filter	0.00 to 2.50 sec		1		NA	F	NA
	N9-18	L Tuning filter	0 to 1000		1000		NA	F	NA
Monitor Selection	O1-01	3th Monitor Selection at Run	4 to 33	6	6	6	A	A	A
	O1-02	Monitor Selection after Power up	1: Frequency Reference 2: Output Frequency 3: Output Current 4: Monitor Item at O1-01	1	1	1	A	A	A
	O1-03	frequency reference selection unit		0	0	0	A	A	A
	O1-04	V/f pattern unit setting parameter for E1-04, 06, 09	0: Hz 1: r/min	0	0	0	NA	NA	A
	O1-05	LCD operator focus	0 to 5	3	3	3	A	A	A
Multi-function Selections	O2-01	Local/Remote Key	0: Disabled 1: enabled	1	1	1	A	A	A
	O2-02	Stop Key	0: Disabled 1: enabled	1	1	1	A	A	A

Yaskawa Electric Europe GmbH
Technical & Marketing Department
Drives Section

	O2-03	OEM/Site default storing	0: not selected 1: Storing 2: clear	0	0	0	A	A	A
Power Settings									
	O2-04	KVA Setting	0 to FF				A	A	A
	O2-05	Frequency referency setting method	0: enter key 1: no enter key	0	0	0	A	A	A
	O2-06	Operator detection	0: Disabled 1: enabled	0	0	0	A	A	A
	O2-07	Commulation Operation time Setting	0 to 65535	OH	OH	OH	A	A	A
	O2-08	Commulation Operation time Setting	0: Power on time 1: Run Time	0	0	0	A	A	A
	O2-09	initialize mode	2: Europa	2	2	2	A	A	A
	O2-10	Fan Operation Time Setting	0 to 65535	0H	0H	0H	A	A	A
	O2-12	Alarm clear selection	0: disabled 1: enabled	0	0	0	A	A	A
	O2-13	PUF continues test selection	0:disabled 1: enabled	1	1	1	F	F	F
	O2-15	r/min initialize selection	0: not initialized 1: initialized	0	0	0	A	A	A
Copy Function									
	O3-01	Copy function	0: Normal Operation 1: Read Inv to operator 2: Copy Operator to Inverter 3: Verify	0	0	0	A	A	A
	O3-02	Read Permission	0: Read Prohibited 1: Read Permitted	0	0	0	A	A	A
	T1-01	Tuning mode selection	0: rotating 1: standing 2: line to line resistance 3: on delay tuning	0	0	0			
	T1-02	Motor output power	0.00 to 650.00						
	T1-03	Motor rated voltage							
	T1-04	Motor rated current							
	T1-05	Motor base frequency							
	T1-06	Number of motor poles	2 to 48	4	4	4			
	T1-07	motor base speed	0 to 24000	1750	1750	1750			
	T1-08	PG puls at tuning	0 to 60000	1024	1024	1024			
	T1-09	no load current setting							
Brake Sequence									
	S1-01	Zero Speed Level at stop	0.0 to 10.0Hz	1.2	0.5	0.1	F	F	F
	S1-02	DC Inj Current at Start	0 to 100% (100%=E2-01)	50%	50%	N.A	A	A	N.A
	S1-03	DC Inj Current at Sop	0 to 100% (100%=E2-01)	50%	50%	N.A	A	A	N.A
	S1-05	DC Inj Time at Stop	0.0 to 10.0 sec	0.6	0.6	0.6	F	F	F
	S1-06	Brake open delay	0.0 to 10.00sec	0.2	0.2	0.2	A	A	A
	S1-07	Brake Closing delay Time	0.0 to 10.00sec	0.1	0.1	0.1	A	A	A

Yaskawa Electric Europe GmbH
Technical & Marketing Department
Drives Section

	S1-08	Motor Current Test Level	0 to 100% (100%=E2-01)	25%	25%	25%	F (A)	F (A)	F (A)
	S1-15	SE2 detect time	0 to 2000ms	700	700	700	A	A	A
	S1-16	Run Delay time	0.00 to 1.00s	0.1	0.1	0.1	A	A	A
	S1-17	DC Inj gain at regeneration	0 to 400%	NA	100	NA	NA	100	NA
	S1-18	DC inj gain at motoric	0 to 400%	NA	20	NA	NA	20	NA
	S1-19	contactor open delay	0.00 to 1.00s	0.1	0.1	0.1	A	A	A
	S1-20	zero servo gain	0 to 100	NA	NA	5	NA	NA	A
	S1-21		0 to 16383	NA	NA	10	NA	NA	A
	S1-22	torque increase time	0 to 5000	NA	NA	500	NA	NA	A
	S1-23	torque lower limit gain	0.500 -10.000	NA	NA	1.000	NA	NA	A
	S1-24	torque upper limit bias	-200 to 200	NA	NA	0.0	NA	NA	A
	S1-25	torque lower limit bias	-200 to 200	NA	NA	0.0	NA	NA	A
	S1-26	DWELL speed	0.0 to 400Hz	0.0	0.0	0.0	A	A	A
	S2-01	Motor Rated rpm	300 to 1800	1380	1380	1380	A	NA	N.A
Slip Compensation	S2-02	Slip Comp. Gain Motoring	0.0 to 2.5	0.7	0.7	0.7	A	A	N.A
	S2-03	Slip Comp. Gain Regenerating	0.0 to 2.5	1.0	1.0	N.A	A	A	N.A
	S2-04	Slip Comp. Limit	0.0 to 250%	200	200	200	NA	F	N.A
	S2-05	Torque Detection Delay Time	0 to 10.0sec	1.0	1.0	NA	F	F	N.A
	S2-06	Torque detection time	0.00 to 2.00 sec	0.5	0.5	NA	F	F	N.A
Slip Compensation	S2-07	Slip Comp. Delay Time	0 to 10000ms	N.A	200	N.A	N.A	A	N.A
	S2-15	slip compensation during generation selection	0: disabled 1: enabled	1	1	NA	F	F	N.A
Short Floor Operation Selection	S3-01	Short floor selection function	0: disabled 1: enabled	0	0	0	A	A	A